



Catalog #	HPS-100R-1
Type:	100W High Pressure Sodium
Voltage:	120V

General Information

Lamp Type	100W HPS
ANSI Designation	S54
Line Voltage (V)	120
Regulation	5%
Frequency (Hz)	60
Recommended Fuse (A)	10
Circuit Type	Reactor
Insulation Class	180°C
Capacitor Value	46 MF for HPF
Capacitor Voltage Rating	120 V
Cap. Temp. Rating	90°C
Winding Materials (Pri/Sec)	Cu/Cu
Lamp Starter	XG-01
Agency Certification	RU, cRU
Maximum Distance to Lamp	3 FT

Wiring Diagram

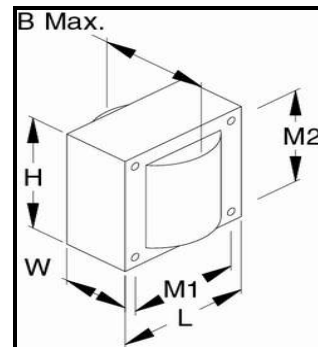
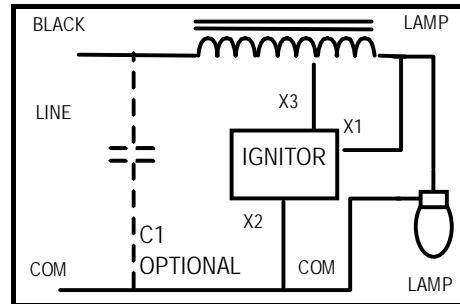

Electrical Characteristics

Line Volt (V)	Power Factor	Line Current (A)			Input Power (W)	Open Circuit Voltage (V)	Min Start Temp.	UL Temp. Code
		Operating	Open	Start				
120	NPF	2.26	NA	2.92	109	120	-40°C	A

Physical Characteristics

Overall Dimensions (Inches)				Mounting Holes (Inches)			Bracket Dimension (Inches)		Ballast Net Weight (KG)	Lead Length (Inches)
Length	Width	Height	B max.	Diameter	M1	M2	Length	Width		
2.64	2.25	1.54	2.72	0.203	2.19	1.79	-	-	1.137	12-14

KEYSTONE TECHNOLOGIES LLC.
P.O. Box 246, AMBLER, PENNSYLVANIA 19002
PHONE: 215-283-2600
FAX: 215-628-4412
INFO@KEYSTONEBALLAST.COM
WWW.KEYSTONEBALLAST.COM